

SITE PLAN

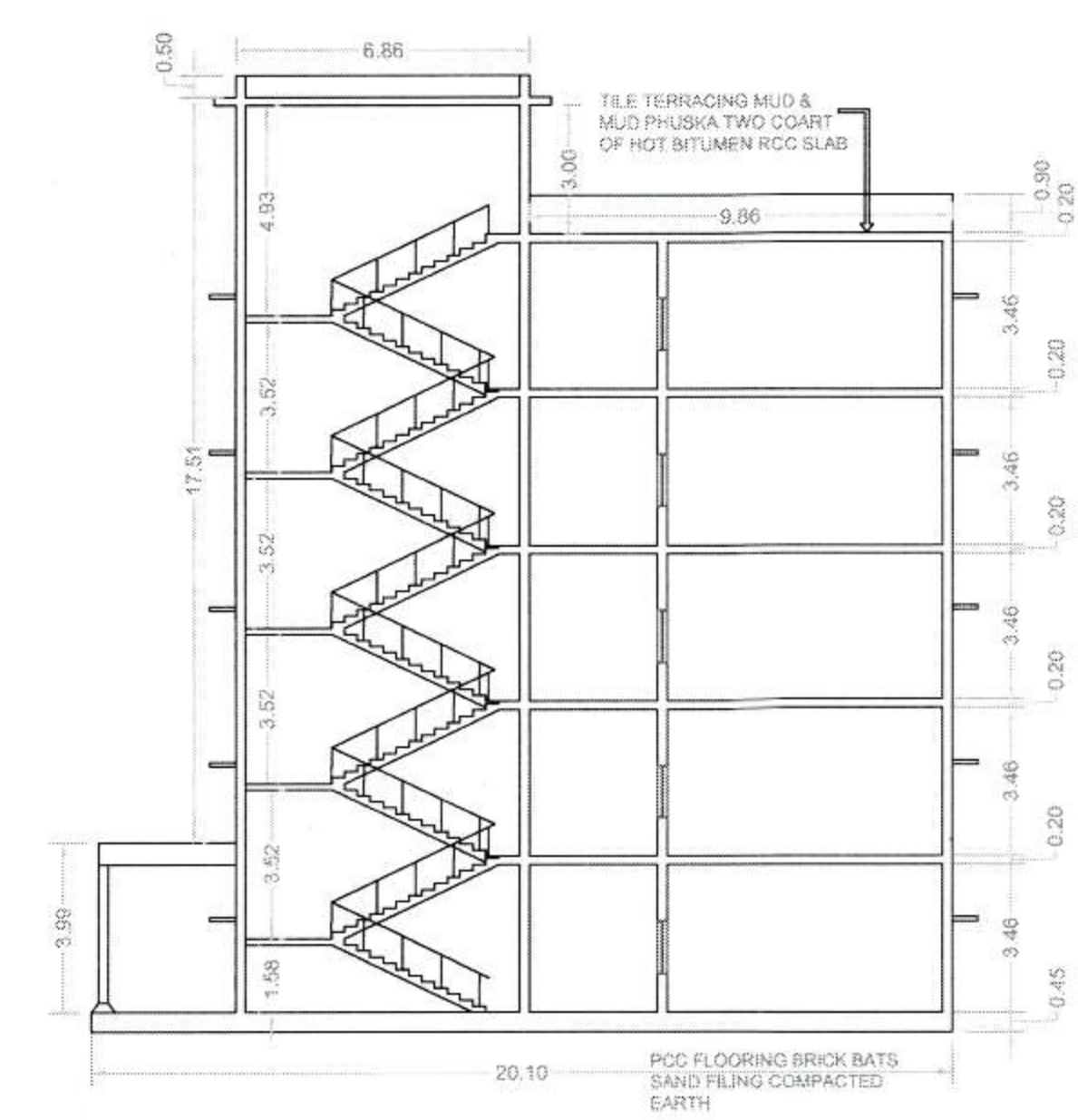

SECTION AT - B-B BLOCK - A

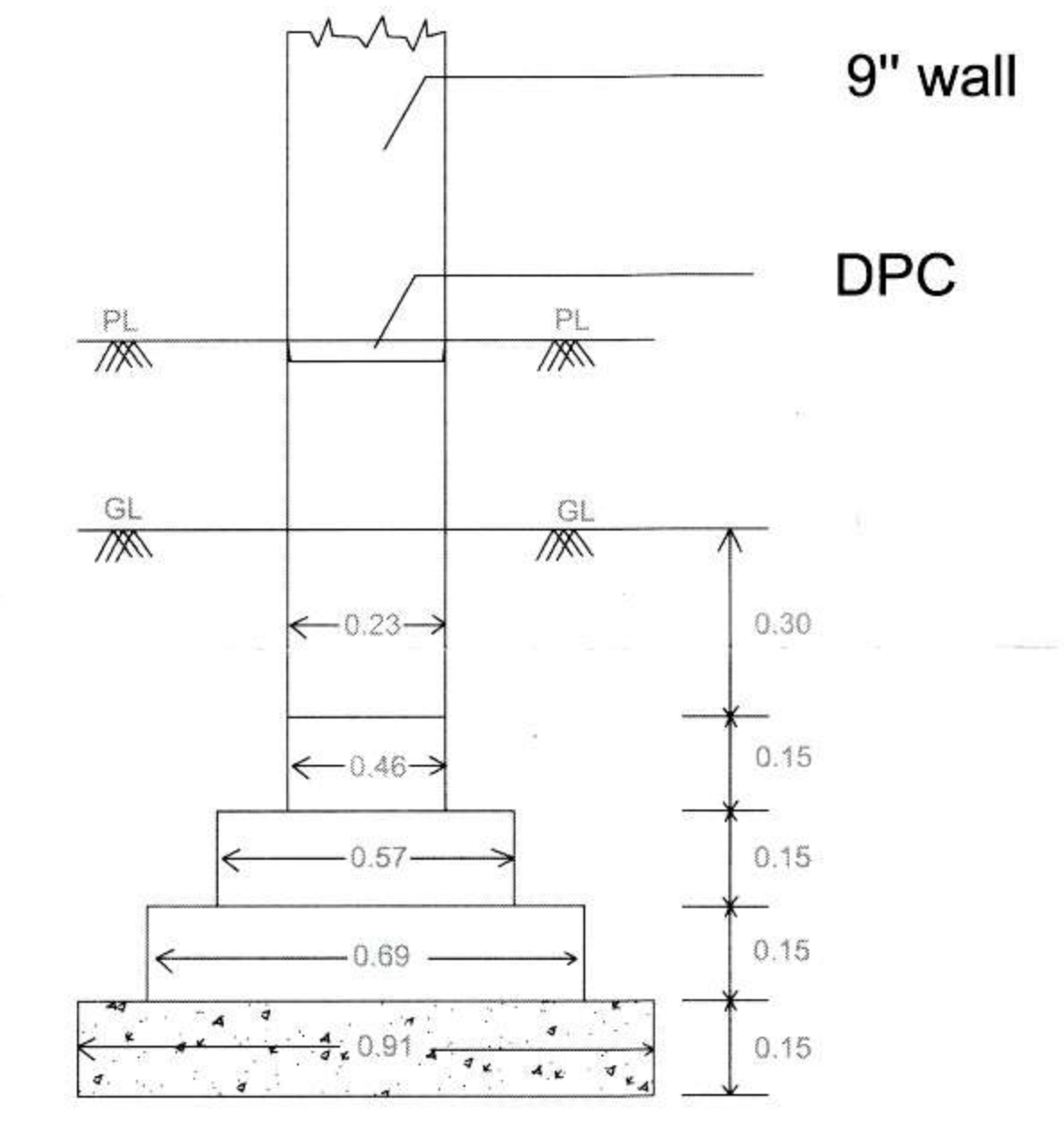

FOUNDATION DETAIL
NOT TO SCALE

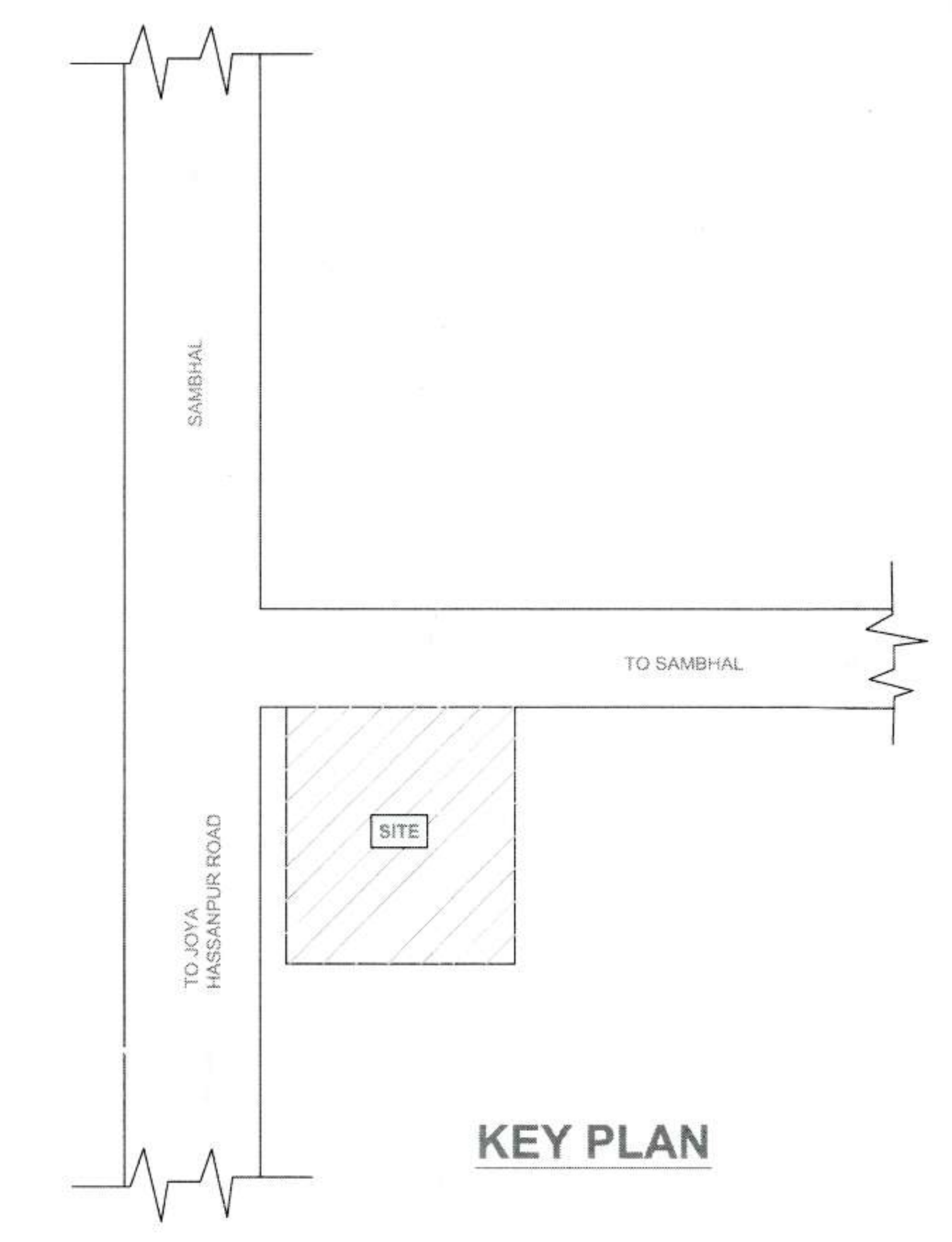
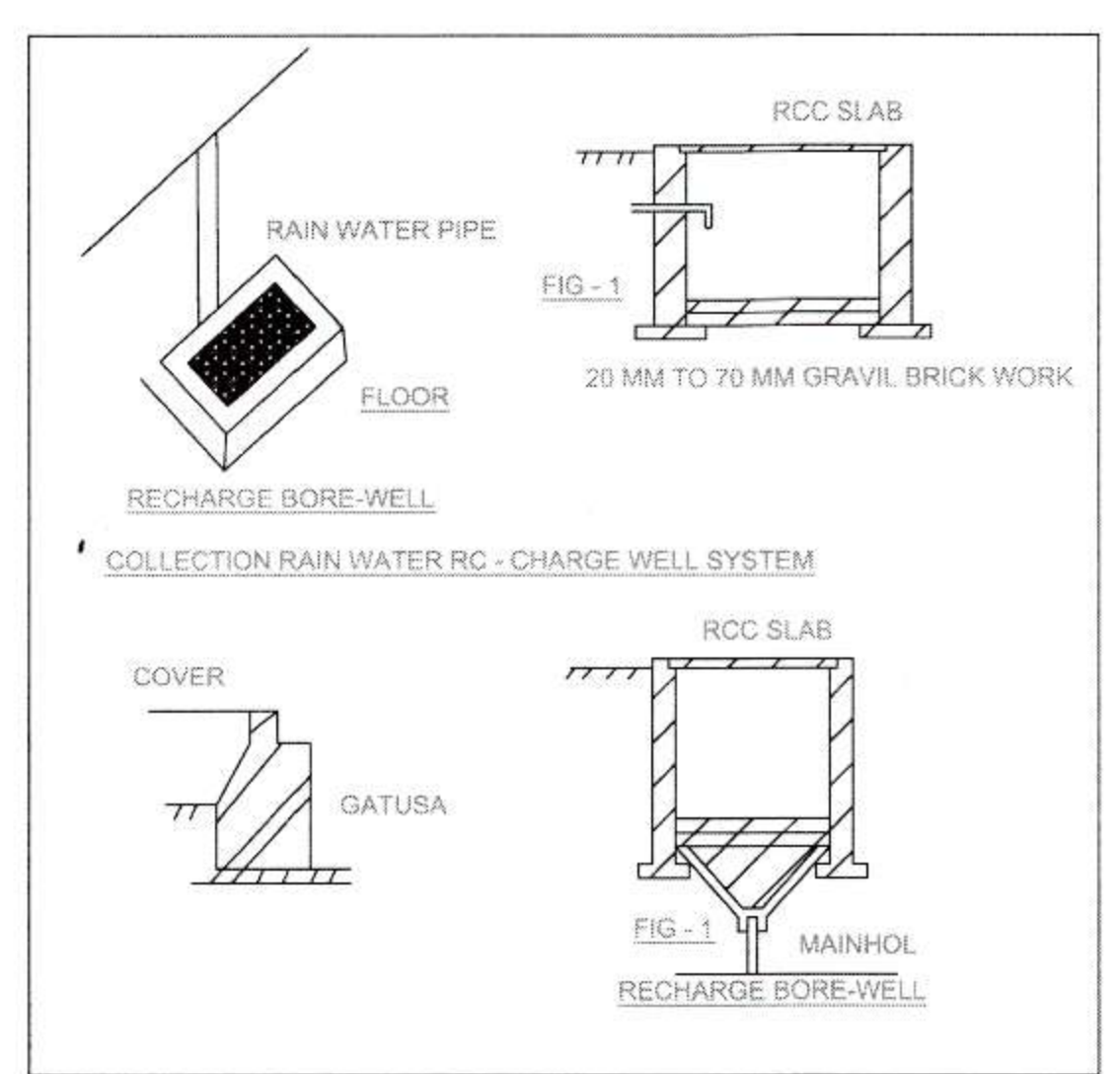

KEY PLAN

SPACE FOR SANCTION
 मानाचक्र स्वीकृती सादर करीत आहे
 नं 0 संख/2020/0175 दि 22/01/2020

अधिकाारी अभियन्ता
 जिला पंचायत
 सम्भल (उ०प्र०)
 उपमुख्य अधिकारी
 जिला पंचायत
 सम्भल (उ०प्र०)

FIRE LEGENDS

SL.NO	DESCRIPTION	SYMBOL'S	REMARKS
1	FIRE EXTINGUISHER (F.E.)	☒	
2	HOSE REEL (H.R.)	○	
3	SPRINKLERS	⊙	
4	SMOKE DETECTOR (S.D.)	⊠	
5	WET RISER	⊞	
6	YARD HYDRANT	⊕	
7	FIRE ALARM	⊞	
8	WATER PUMP	⊞	
9	UNDER GROUND WATER TANK	⊞	10,000 LITER
10	OVER HEAD WATER TANK	⊞	10,000 LITER

SPECIFICATION :

FOUNDATION	CEMENT & CONC. 1:4:8
WALLS	1st CLASS BRICKS IN WALL
DOORS/WINDOWS	IRON FRAMES & WOODEN
STAIRS	R.C.C. WORK
ROOF	R.C.C. SLAB
PLASTER	CEMENT & SAND MORTAR
FINISHING	WHITE & COLOUR WASHING

AREA STATEMENT

	SQM	%AGE
TOTAL PLOT AREA	6560.00	100.00
EXISTING COVID AREA BLOCK A - L.G.F.	1121.58	17.09
EXISTING COVID AREA BLOCK A - U.G.F.	1134.89	17.30
EXISTING COVID AREA BLOCK A - F.F.	1121.58	17.09
PROPOSED COVID AREA BLOCK A - S.F.	1121.58	17.09
PROPOSED COVID AREA BLOCK A - T.F.	1121.58	17.09
ALL EXISTING & PROPOSED COVID AREA BLOCK A.	5621.21	85.69
EXISTING COVID AREA BLOCK B - O.F.	63.61	0.97
TOTAL OPEN AREA GROUND FLOOR	5361.50	81.73
TOTAL EXIST. & COVID AREA ALL BLOCK (A+B) AND ALL FLOOR (L.G.F.+U.G.F.+F.F.+S.F.+T.F.)	5684.82	86.66
PERMISSIBLE COVID AREA	6560.00	100.00
ARCHIVE FAR @ 1:00	5684.82	86.66

SCHEDULED OF DOORS/WINDOWS :

MD	MAIN DOOR	(3.00X2.438M)
D	DOOR	(1.218X2.134M)
D1	DOOR	(1.00X2.134M)
D2	DOOR	(1.51X2.134M)
W	WINDOW	(1.52X1.219M)
W1	WINDOW	(1.22X1.219M)
V	VENTILATOR	(0.61X0.60 M)
V1	VENTILATOR	(1.00X0.60 M)

REFERENCE :

- PROPOSED CONSTRUCTION
- OTHER PROPERTY
- DRAINAGE WORK

TITLE
 EXISTING & PROPOSED BUILDING PLAN ON
 GATA NO - 23, 3
 TOTAL PLOT AREA 0.8100 HECTARE (8100.00 SQM).
 SITUATED AT - DARWAJA BAHRI CHUNGI,
 JOYA-HASSANPUR ROAD, SAMBHAL (U.P.) 244302
 BELONGING TO - NATURAL COLLEGE OF
 SCIENCE & TECHNOLOGY

OWNERS :
 KEY FOUNDATION
 F.NO-339, 1st FLOOR, STREET NO.12
 GHAFAR MANZIL, JAMIA NAGAR, OKHLA
 NEW DELHI 110025

NORTH :
 N
 OWNER'S SIGN

SCALE > 1:200
 FILE NAME >
 DRN BY >

ARCHITECTS :
 VIJAY GUPTA
 B. Arch.
 C.A.No. 75/1916

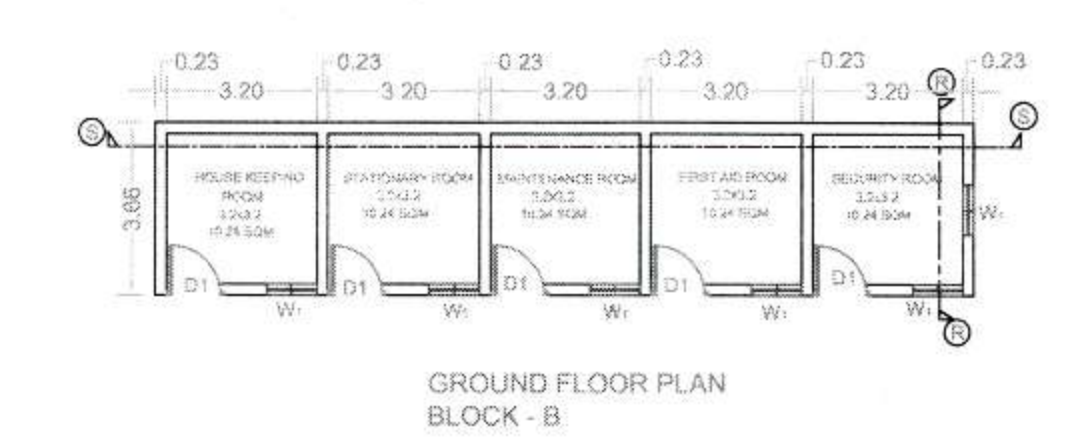

GROUND FLOOR PLAN BLOCK - B

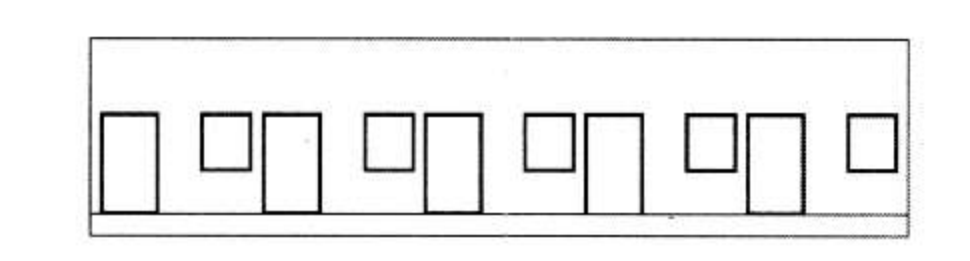

FRONT ELEVATION Block - B

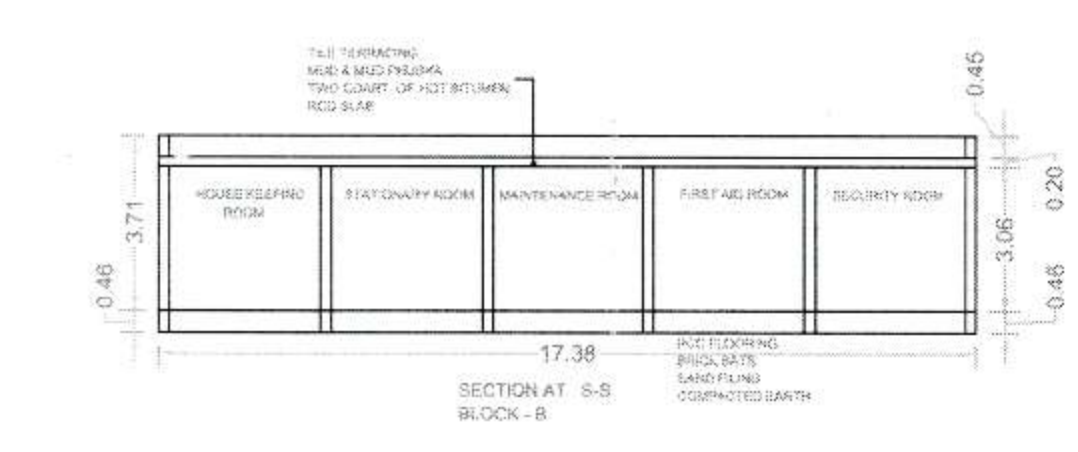

SECTION AT - A-A BLOCK - B

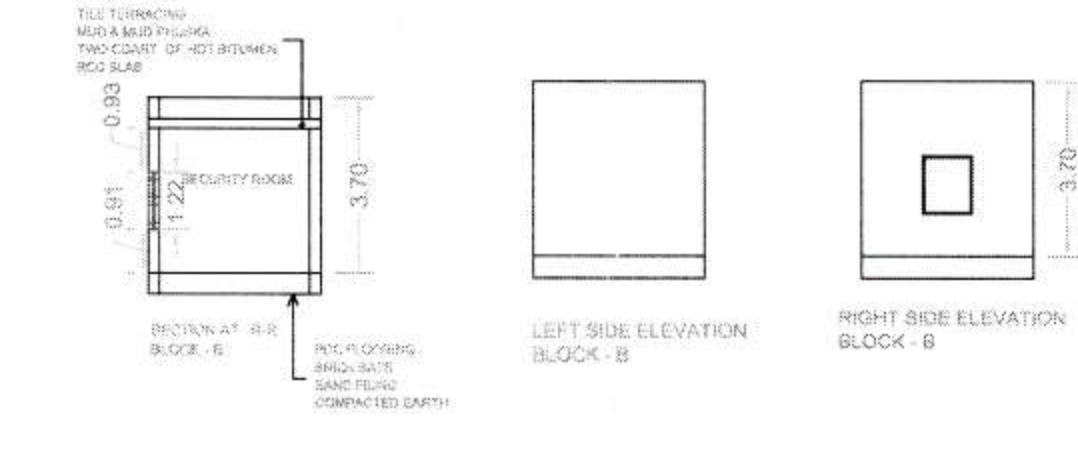

LEFT SIDE ELEVATION BLOCK - B
RIGHT SIDE ELEVATION BLOCK - B

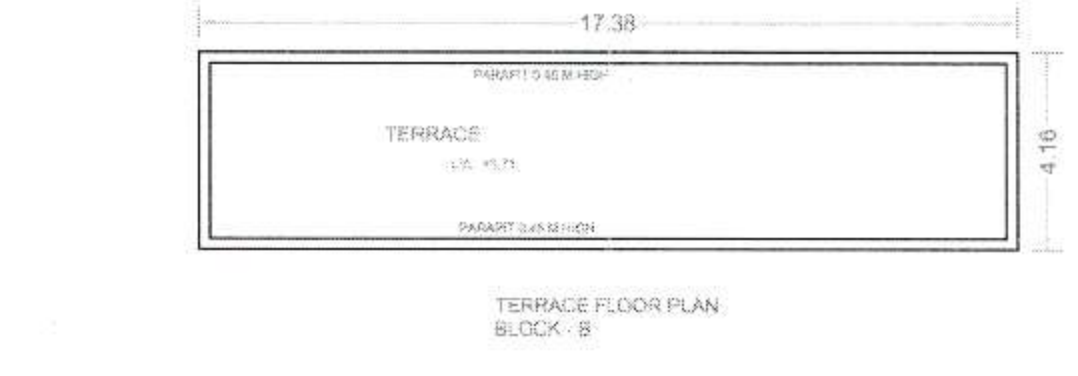

TERENCE FLOOR PLAN BLOCK - B